



S-9000 MK-4 AND S-8000 SAND FILTERS

COMMERICAL/DOMESTIC

Designed for domestic & commercial installation with industrial strength polymer for strength & durability

WHEN PERFORMANCE COUNTS



Industrial strength polymer sand filters

Thousands of commercial and domestic installations over the last two decades bear testament to the quality and reliability of the Poolrite filter.

Features of the S-9000 MK4 and S-8000 Filters

- One piece seamless rotationally moulded tank designed for maximum strength
- Made from high density polyethylene for strength & durability
- Poolrite's overdrain is designed for smooth, even flow of water into the filter tank
- Poolrite's underdrain ensures maximum backwashing power for longer filter cycles
- All non-corrosive construction suitable for all types of sanitation
- Australian design & manufacture

SMARTVALVE™ – exclusive to S-8000

- Gives an audible signal when backwashing is required
- Pressure adjustable to suit all plumbing configurations
- 50mm ports for larger water flow
- Large diameter valve for more water flow and quieter operation
- Weather cover to prevent debris buildup around valve stem thus ensuring easy operation & longer life
- Gasket mounted to selector plate – no "spider" gasket required
- Large ergonomically designed handle for easy operation
- Fitted with 50mm pump unions allowing quick connection and simplified servicing
- Battery test switch

S-9000 MK4

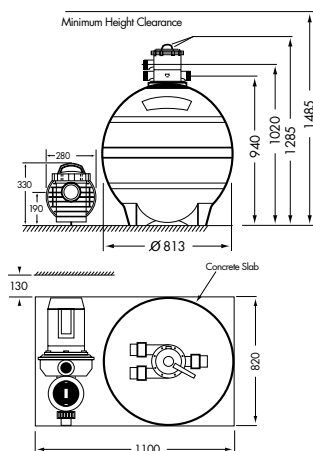

S-9000 Specification Chart

Max Flow Rate LPH	33,000
Sand weight kg (lbs)	200 (441)
Sand grade mm	-1.2+0.6
Coarse media kg (lbs)	60 (132)
Filter tank dia. mm (in)	813 (32)

Poolrite pump model	(Hp)	Input	Output
SQI 600	1.50	1550w	1100w
SQI 700	2.00	2000w	1500w
DP 375	1.25	1300w	930w
DP 450	1.50	1550w	1100w

S-8000

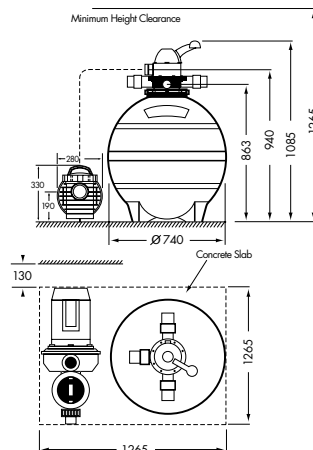

S-8000 Specification Chart

Max Flow Rate LPH	27,000
Sand weight kg (lbs)	140 (308)
Sand grade mm	-1.2+0.6
Coarse Media kg (lbs)	60 (132)
Filter tank dia. mm (in)	740 (30)

Poolrite pump model	(Hp)	Input	Output
SQI 600	1.50	1550w	1100w
SQI 700	2.00	2000w	1500w
DP 375	1.25	1300w	930w
DP 450	1.50	1550w	1100w

Warranty:

- 10 year filter tank warranty
- All other components carry a 12 month warranty.

For good clean fun!



Get it right!

AUSTRALIA
HEAD OFFICE – QLD: 415 Creek Road MT GRAVATT 4122
 Telephone: (07) 3323 6555, Fax: (07) 3323 6500

Nth QLD: 36 Hugh Ryan Drive GARBUTT 4814
 Telephone: (07) 4779 4880, Fax: (07) 4779 6714

NSW: 6 Forsyth Close WETHERILL PARK 2164
 Telephone: (02) 9729 0166, Fax: (02) 9729 2759

VIC: 1 Endeavour Way BRAESIDE 3195
 Telephone: (03) 9588 1770, Fax: (03) 9588 1779

WA: 16 Ledger Road BALCATTA 6021
 Telephone: (08) 9344 3871, Fax: (08) 9345 3923

NEW ZEALAND
 22/761 Great South Road, Penrose AUCKLAND
 Telephone (09) 571 0210, Fax: 0800 766 574

Manufactured by Poolrite Equipment Pty Ltd ABN 11 001 674 004 Website: www.poolrite.com.au Email: info@poolrite.com.au

Manufacturer reserves the right to alter specifications without notice.